



## Standard Test Methods for Laboratory Compaction Characteristics of Soil Using Modified Effort (56,000 ft-lbf/ft<sup>3</sup> (2,700 kN-m/m<sup>3</sup>))<sup>1</sup>

This standard is issued under the fixed designation D 1557; the number immediately following the designation indicates the year of original adoption or, in the case of revision, the year of last revision. A number in parentheses indicates the year of last reapproval. A superscript epsilon ( $\epsilon$ ) indicates an editorial change since the last revision or reapproval.

<sup>ε1</sup> NOTE—Paragraph 10.4.3 was corrected editorially in November 2003.

### 1. Scope\*

1.1 These test methods cover laboratory compaction methods used to determine the relationship between water content and dry unit weight of soils (compaction curve) compacted in a 4- or 6-in. (101.6 or 152.4 mm) diameter mold with a 10-lbf. (44.5-N) rammer dropped from a height of 18 in. (457 mm) producing a compactive effort of 56,000 ft-lbf/ft<sup>3</sup> (2,700 kN-m/m<sup>3</sup>).

NOTE 1—Soils and soil-aggregate mixtures should be regarded as natural occurring fine- or coarse-grained soils or composites or mixtures of natural soils, or mixtures of natural and processed soils or aggregates such as silt, gravel, or crushed rock.

NOTE 2—The equipment and procedures are the same as proposed by the U.S. Corps of Engineers in 1945. The modified effort test (see 3.2.2) is sometimes referred to as the Modified Proctor Compaction Test.

1.2 These test methods apply only to soils (materials) that have 30 % or less by mass of their particles retained on the ¾-in. (19.0-mm) sieve.

NOTE 3—For relationships between unit weights and water contents of soils with 30 % or less by weight of material retained on the ¾-in. (19.0-mm) sieve to unit weights and water contents of the fraction passing the ¾-in. (19.0-mm) sieve, see Practice D 4718.

1.3 Three alternative methods are provided. The method used shall be as indicated in the specification for the material being tested. If no method is specified, the choice should be based on the material gradation.

#### 1.3.1 Method A:

1.3.1.1 *Mold*—4-in. (101.6-mm) diameter.

1.3.1.2 *Material*—Passing No. 4 (4.75-mm) sieve.

1.3.1.3 *Layers*—Five.

1.3.1.4 *Blows per layer*—25.

1.3.1.5 *Use*—May be used if 20 % or less by mass of the material is retained on the No. 4 (4.75-mm) sieve.

1.3.1.6 *Other Use*—If this method is not specified, materials that meet these gradation requirements may be tested using Methods B or C.

#### 1.3.2 Method B:

1.3.2.1 *Mold*—4-in. (101.6-mm) diameter.

1.3.2.2 *Material*—Passing ¾-in. (9.5-mm) sieve.

1.3.2.3 *Layers*—Five.

1.3.2.4 *Blows per layer*—25.

1.3.2.5 *Use*—Shall be used if more than 20 % by mass of the material is retained on the No. 4 (4.75-mm) sieve and 20 % or less by mass of the material is retained on the ¾-in. (9.5-mm) sieve.

1.3.2.6 *Other Use*—If this method is not specified, materials that meet these gradation requirements may be tested using Method C.

#### 1.3.3 Method C:

1.3.3.1 *Mold*—6-in. (152.4-mm) diameter.

1.3.3.2 *Material*—Passing ¾-in. (19.0-mm) sieve.

1.3.3.3 *Layers*—Five.

1.3.3.4 *Blows per layer*—56.

1.3.3.5 *Use*—Shall be used if more than 20 % by mass of the material is retained on the ¾-in. (9.53-mm) sieve and less than 30 % by mass of the material is retained on the ¾-in. (19.0-mm) sieve.

1.3.4 The 6-in. (152.4-mm) diameter mold shall not be used with Method A or B.

NOTE 4—Results have been found to vary slightly when a material is tested at the same compactive effort in different size molds.

1.4 If the test specimen contains more than 5 % by mass of oversize fraction (coarse fraction) and the material will not be included in the test, corrections must be made to the unit weight and water content of the test specimen or to the appropriate field in place density test specimen using Practice D 4718.

1.5 This test method will generally produce well defined maximum dry unit weight for non-free draining soils. If this test method is used for free draining soils the maximum unit

<sup>1</sup> This standard is under the jurisdiction of ASTM Committee D18 on Soil and Rock and is the direct responsibility of Subcommittee D18.03 on Texture, Plasticity and Density Characteristics of Soils.

Current edition approved Nov. 10, 2002. Published January 2003. Originally published as D 1557 – 58. Last previous edition D 1557 – 00.

weight may not be well defined, and can be less than obtained using Test Methods D 4253.

1.6 The values in inch-pound units are to be regarded as the standard. The values stated in SI units are provided for information only.

1.6.1 In the engineering profession it is customary practice to use, interchangeably, units representing both mass and force, unless dynamic calculations ( $F = Ma$ ) are involved. This implicitly combines two separate systems of units, that is, the absolute system and the gravimetric system. It is scientifically undesirable to combine the use of two separate systems within a single standard. This test method has been written using inch-pound units (gravimetric system) where the pound (lbf) represents a unit of force. The use of mass (lbm) is for convenience of units and is not intended to convey the use is scientifically correct. Conversions are given in the SI system in accordance with IEEE/ASTM SI 10. The use of balances or scales recording pounds of mass (lbm), or the recording of density in lbm/ft<sup>3</sup> should not be regarded as nonconformance with this standard.

1.7 *This standard does not purport to address all of the safety concerns, if any, associated with its use. It is the responsibility of the user of this standard to establish appropriate safety and health practices and determine the applicability of regulatory limitations prior to use.*

## 2. Referenced Documents

### 2.1 ASTM Standards:

- C 127 Test Method for Specific Gravity and Absorption of Coarse Aggregate<sup>2</sup>
- C 136 Test Method for Sieve Analysis of Fine and Coarse Aggregates<sup>2</sup>
- D 422 Test Method for Particle-Size Analysis of Soils<sup>3</sup>
- D 653 Terminology Relating to Soil, Rock, and Contained Fluids<sup>3</sup>
- D 698 Test Method for Laboratory Compaction Characteristics of Soil Using Standard Effort [12,400 ft-lbf/ft<sup>3</sup> (600 kN-mJ/m<sup>3</sup>)]<sup>3</sup>
- D 854 Test Method for Specific Gravity of Soils<sup>3</sup>
- D 2168 Test Methods for Calibration of Laboratory Mechanical-Rammer Soil Compactors<sup>3</sup>
- D 2216 Test Method for Laboratory Determination of Water (Moisture) Content of Soil and Rock by Mass<sup>3</sup>
- D 2487 Practice for Classification of Soils for Engineering Purposes (Unified Soil Classification System)<sup>3</sup>
- D 2488 Practice for Description and Identification of Soils (Visual-Manual Procedure)<sup>3</sup>
- D 3740 Practice for Minimum Requirements for Agencies Engaged in the Testing and/or Inspection of Soil and Rock as Used in Engineering Design and Construction<sup>3</sup>
- D 4220 Practices for Preserving and Transporting Soil Samples<sup>3</sup>
- D 4253 Test Methods for Maximum Index Density of Soils Using a Vibratory Table<sup>3</sup>
- D 4718 Practice for Correction of Unit Weight and Water

Content for Soils Containing Oversize Particles<sup>3</sup>

D 4753 Specification for Evaluating, Selecting and Specifying Balances and Scales For Use in Soil, Rock, and Construction Materials Testing<sup>3</sup>

D 4914 Test Methods for Density of Soil and Rock in Place by the Sand Replacement Method in a Test Pit<sup>3</sup>

D 5030 Test Method for Density of Soil and Rock in Place by the Water Replacement Method in a Test Pit<sup>4</sup>

E 1 Specification for ASTM Thermometers<sup>5</sup>

E 11 Specification for Wire-Cloth Sieves for Testing Purposes<sup>5</sup>

E 319 Practice for the Evaluation of Single-Pan Mechanical Balances<sup>5</sup>

IEEE/ASTM SI 10 Standard for Use of the International System of Units (SI): The Modern Metric System

## 3. Terminology

3.1 *Definitions*—See Terminology D 653 for general definitions.

3.2 *Definitions of Terms Specific to This Standard:*

3.2.1 *modified effort*—the term for the 56 000 ft-lbf/ft<sup>3</sup> (2700 kN-m/m<sup>3</sup>) compactive effort applied by the equipment and methods of this test.

3.2.2 *modified maximum dry unit weight,  $\gamma_{dmax}$*  (lbf/ft<sup>3</sup> (kN/m<sup>3</sup>))—the maximum value defined by the compaction curve for a compaction test using modified effort.

3.2.3 *modified optimum water content,  $w_o$*  (%)—the water content at which the soil can be compacted to the maximum dry unit weight using modified compactive effort.

3.2.4 *oversize fraction (coarse fraction),  $P_c$*  (%)—the portion of total sample not used in performing the compaction test; it may be the portion of total sample retained on the No. 4 (4.75-mm),  $\frac{3}{8}$ -in. (9.5-mm), or  $\frac{3}{4}$ -in. (19.0-mm) sieve.

3.2.5 *test fraction (finer fraction),  $P_F$*  (%)—the portion of the total sample used in performing the compaction test; it may be fraction passing the No. 4 (4.75-mm) sieve in Method A, minus  $\frac{3}{8}$ -in. (9.5-mm) sieve in Method B, or minus  $\frac{3}{4}$ -in. (19.0-mm) sieve in Method C.

## 4. Summary of Test Method

4.1 A soil at a selected water content is placed in five layers into a mold of given dimensions, with each layer compacted by 25 or 56 blows of a 10-lbf (44.5-N) rammer dropped from a distance of 18-in. (457-mm), subjecting the soil to a total compactive effort of about 56 000 ft-lbf/ft<sup>3</sup> (2700 kN-m/m<sup>3</sup>). The resulting dry unit weight is determined. The procedure is repeated for a sufficient number of water contents to establish a relationship between the dry unit weight and the water content for the soil. This data, when plotted, represent a curvilinear relationship known as the compaction curve. The values of optimum water content and modified maximum dry unit weight are determined from the compaction curve.

## 5. Significance and Use

5.1 Soil placed as engineering fill (embankments, foundation pads, road bases) is compacted to a dense state to obtain

<sup>2</sup> Annual Book of ASTM Standards, Vol 04.02.

<sup>3</sup> Annual Book of ASTM Standards, Vol 04.08.

<sup>4</sup> Annual Book of ASTM Standards, Vol 04.09.

<sup>5</sup> Annual Book of ASTM Standards, Vol 14.02.

satisfactory engineering properties such as, shear strength, compressibility, or permeability. Also, foundation soils are often compacted to improve their engineering properties. Laboratory compaction tests provide the basis for determining the percent compaction and water content needed to achieve the required engineering properties, and for controlling construction to assure that the required compaction and water contents are achieved.

5.2 During design of an engineered fill, shear, consolidation, permeability, or other tests require preparation of test specimens by compacting at some water content to some unit weight. It is common practice to first determine the optimum water content ( $w_o$ ) and maximum dry unit weight ( $\gamma_{dmax}$ ) by means of a compaction test. Test specimens are compacted at a selected water content ( $w$ ), either wet or dry of optimum ( $w_o$ ) or at optimum ( $w_o$ ), and at a selected dry unit weight related to a percentage of maximum dry unit weight ( $\gamma_{dmax}$ ). The selection of water content ( $w$ ), either wet or dry of optimum ( $w_o$ ) or at optimum ( $w_o$ ) and the dry unit weight ( $\gamma_{dmax}$ ) may be based on past experience, or a range of values may be investigated to determine the necessary percent of compaction.

5.3 Experience indicates that the methods outlined in 5.2 or the construction control aspects discussed in 5.1 are extremely difficult to implement or yield erroneous results when dealing with some soils. The following subsections describe typical problem soils, the problems encountered when dealing with such soils and possible solutions for these problems.

5.3.1 *Oversize Fraction*—Soils containing more than 30 % oversize fraction (material retained on the  $\frac{3}{4}$ -in. (19-mm) sieve) are a problem. For such soils, there is no ASTM test method to control their compaction and very few laboratories are equipped to determine the laboratory maximum unit weight (density) of such soils (USDI Bureau of Reclamation, Denver, CO and U.S. Army Corps of Engineers, Vicksburg, MS). Although Test Methods D 4914 and D 5030 determine the “field” dry unit weight of such soils, they are difficult and expensive to perform.

5.3.1.1 One method to design and control the compaction of such soils is to use a test fill to determine the required degree of compaction and the method to obtain that compaction. Then use a method specification to control the compaction. Components of a method specification typically contain the type and size of compaction equipment to use, the lift thickness, and number of passes.

NOTE 5—Success in executing the compaction control of an earthwork project, especially when a method specification is used, is highly dependent upon the quality and experience of the “contractor” and “inspector”.

5.3.1.2 Another method is to apply the use of density correction factors developed by the USDI Bureau of Reclamation (1,2)<sup>6</sup> and U.S. Corps of Engineers (3). These correction factors may be applied for soils containing up to about 50 to 70 % oversize fraction. Both agencies use a different term for these density correction factors. The USDI Bureau of Recla-

mation uses  $D$  ratio (or  $D$  – VALUE), while the U.S. Corps of Engineers uses Density Interference Coefficient ( $I_c$ ).

5.3.1.3 The use of the replacement technique (Test Method D 1557–78, Method D), in which the oversize fraction is replaced with a finer fraction, is inappropriate to determine the maximum dry unit weight,  $\gamma_{dmax}$ , of soils containing oversize fractions (3).

5.3.2 *Degradation*—Soils containing particles that degrade during compaction are a problem, especially when more degradation occurs during laboratory compaction than field compaction, the typical case. Degradation typically occurs during the compaction of a granular-residual soil or aggregate. When degradation occurs, the maximum dry-unit weight increases (4) so that the resulting laboratory maximum value is not representative of field conditions. Often, in these cases, the maximum dry unit weight is impossible to achieve in the field.

5.3.2.1 Again for soils subject to degradation, the use of test fills and method specifications may help. Use of replacement techniques is not correct.

5.3.3 *Gap Graded*—Gap-graded soils (soils containing many large particles with limited small particles) are a problem because the compacted soil will have larger voids than usual. To handle these large voids, standard test methods (laboratory or field) typically have to be modified using engineering judgement.

NOTE 6—The quality of the result produced by this standard is dependent on the competence of the personnel performing it, and the suitability of the equipment and facilities used. Agencies that meet the criteria of Practice D 3740 are generally considered capable of competent and objective testing/sampling/inspection/etc. Users of this standard are cautioned that compliance with Practice D 3740 does not in itself assure reliable results. Reliable results depend on many factors; Practice D 3740 provides a means of evaluating some of those factors.

## 6. Apparatus

6.1 *Mold Assembly*—The molds shall be cylindrical in shape, made of rigid metal and be within the capacity and dimensions indicated in 6.1.1 or 6.1.2 and Fig. 1 and Fig. 2. The walls of the mold may be solid, split, or tapered. The “split” type, may consist of two half-round sections, or a section of pipe split along one element, which can be securely locked together to form a cylinder meeting the requirements of this section. The “tapered” type shall an internal diameter taper that is uniform and not more than 0.200 in./ft (16.7 mm/m) of mold height. Each mold shall have a base plate and an extension collar assembly, both made of rigid metal and constructed so they can be securely attached and easily detached from the mold. The extension collar assembly shall have a height extending above the top of the mold of at least 2.0 in. (50.8 mm) which may include an upper section that flares out to form a funnel provided there is at least a 0.75-in. (19.0-mm) straight cylindrical section beneath it. The extension collar shall align with the inside of the mold. The bottom of the base plate and bottom of the centrally recessed area that accepts the cylindrical mold shall be planar.

6.1.1 *Mold, 4 in.*—A mold having a  $4.000 \pm 0.016$ -in. ( $101.6 \pm 0.4$ -mm) average inside diameter, a height of  $4.584 \pm 0.018$  in. ( $116.4 \pm 0.5$  mm) and a volume of  $0.0333 \pm 0.0005$

<sup>6</sup> The boldface numbers in parentheses refer to the list of references at the end of this standard.

As an option to the full length stud, a 2 1/2" x 3/8" stud may be used. Then as an alternative construction, the collar may be held down with a slotted bracket attached to the collar and a pin in the mold.

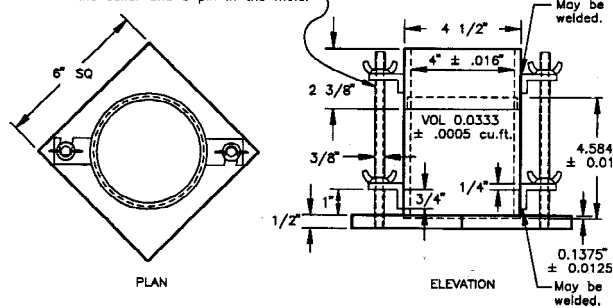

NOTE 1—See Table 2 for metric equivalents.

FIG. 1 Cylindrical Mold, 4.0-in.

As an option to the full length stud, a 2 1/2" x 3/8" stud may be used. Then as an alternative construction, the collar may be held down with a slotted bracket attached to the collar and a pin in the mold.

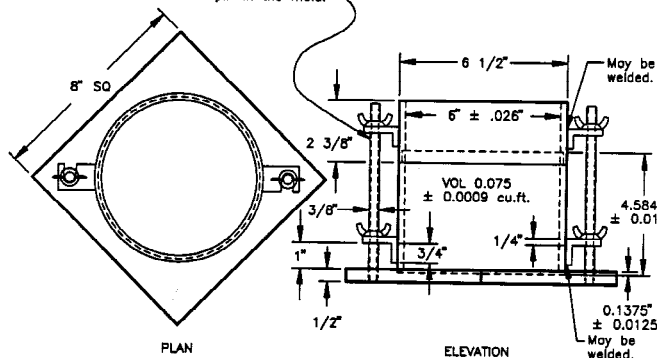

NOTE 1—See Table 2 for metric equivalents.

FIG. 2 Cylindrical Mold, 6.0-in.

ft<sup>3</sup> (944 ± 14 cm<sup>3</sup>). A mold assembly having the minimum required features is shown in Fig. 1.

6.1.2 *Mold, 6 in.*—A mold having a 6.000 ± 0.026 in. (152.4 ± 0.7 mm) average inside diameter, a height of 4.584 ± 0.018 in. (116.4 ± 0.5 mm), and a volume of 0.075 ± 0.0009 ft<sup>3</sup> (2124 ± 25 cm<sup>3</sup>). A mold assembly having the minimum required features is shown in Fig. 2.

6.2 *Rammer*—A rammer, either manually operated as described further in 6.2.1 or mechanically operated as described in 6.2.2. The rammer shall fall freely through a distance of 18 ± 0.05 in. (457.2 ± 1.3 mm) from the surface of the specimen. The mass of the rammer shall be 10 ± 0.02 lbm (4.54 ± 0.01 kg), except that the mass of the mechanical rammers may be adjusted as described in Test Methods D 2168 (see Note 7). The striking face of the rammer shall be planar and circular, except as noted in 6.2.2.1, with a diameter when new of 2.000 ± 0.005 in. (50.80 ± 0.13 mm). The rammer shall be replaced if the striking face becomes worn or bellied to the extent that the diameter exceeds 2.000 ± 0.01 in. (50.80 ± 0.25 mm).

NOTE 7—It is a common and acceptable practice in the inch-pound system to assume that the mass of the rammer is equal to its mass determined using either a kilogram or pound balance and 1 lbf is equal to 1 lbm or 0.4536 kg or 1 N is equal to 0.2248 lbm or 0.1020 kg.

6.2.1 *Manual Rammer*—The rammer shall be equipped with a guide sleeve that has sufficient clearance that the free

fall of the rammer shaft and head is not restricted. The guide sleeve shall have at least four vent holes at each end (eight holes total) located with centers 3/4 ± 1/16 in. (19.0 ± 1.6 mm) from each end and spaced 90° apart. The minimum diameter of the vent holes shall be 3/8 in. (9.5 mm). Additional holes or slots may be incorporated in the guide sleeve.

6.2.2 *Mechanical Rammer-Circular Face*—The rammer shall operate mechanically in such a manner as to provide uniform and complete coverage of the specimen surface. There shall be 0.10 ± 0.03-in. (2.5 ± 0.8-mm) clearance between the rammer and the inside surface of the mold at its smallest diameter. The mechanical rammer shall meet the calibration requirements of Test Methods D 2168. The mechanical rammer shall be equipped with a positive mechanical means to support the rammer when not in operation.

6.2.2.1 *Mechanical Rammer-Sector Face*—When used with the 6.0-in. (152.4-mm) mold, a sector face rammer may be used in place of the circular face rammer. The specimen contact face shall have the shape of a sector of a circle of radius equal to 2.90 ± 0.02 in. (73.7 ± 0.5 mm). The rammer shall operate in such a manner that the vertex of the sector is positioned at the center of the specimen.

6.3 *Sample Extruder (optional)*—A jack, frame or other device adapted for the purpose of extruding compacted specimens from the mold.



6.4 *Balance*—A class GP5 balance meeting the requirements of Specification D 4753 for a balance of 1-g readability.

6.5 *Drying Oven*—Thermostatically controlled, preferably of a forced-draft type and capable of maintaining a uniform temperature of  $230 \pm 9^\circ\text{F}$  ( $110 \pm 5^\circ\text{C}$ ) throughout the drying chamber.

6.6 *Straightedge*—A stiff metal straightedge of any convenient length but not less than 10 in. (254 mm). The total length of the straightedge shall be machined straight to a tolerance of  $\pm 0.005$  in. ( $\pm 0.1$  mm). The scraping edge shall be beveled if it is thicker than  $\frac{1}{8}$  in. (3 mm).

6.7 *Sieves*— $\frac{3}{4}$  in. (19.0 mm),  $\frac{3}{8}$  in. (9.5 mm), and No. 4 (4.75 mm), conforming to the requirements of Specification E 11.

6.8 *Mixing Tools*—Miscellaneous tools such as mixing pan, spoon, trowel, spatula, spray bottle, etc., or a suitable mechanical device for thoroughly mixing the sample of soil with increments of water.

## 7. Calibration

7.1 Perform calibrations before initial use, after repairs or other occurrences that might affect the test results, at intervals not exceeding 1000 test specimens, or annually, whichever occurs first, for the following apparatus:

7.1.1 *Balance*—Evaluate in accordance with Specification D 4753.

7.1.2 *Molds*—Determine the volume as described in Annex A1.

7.1.3 *Manual Rammer*—Verify the free fall distance, rammer mass, and rammer face in accordance with 6.2. Verify the guide sleeve requirements in accordance with 6.2.1.

7.1.4 *Mechanical Rammer*—Calibrate and adjust the mechanical rammer in accordance with Test Methods D 2168. In addition, the clearance between the rammer and the inside surface of the mold shall be verified in accordance with 6.2.2.

## 8. Test Sample

8.1 The required sample mass for Methods A and B is approximately 35 lbm (16 kg), and for Method C is approximately 65 lbm (29 kg) of dry soil. Therefore, the field sample should have a moist mass of at least 50 lbm (23 kg) and 100 lbm (45 kg), respectively.

8.2 Determine the percentage of material (by mass) retained on the No. 4 (4.75-mm),  $\frac{3}{8}$ -in. (9.5-mm), or  $\frac{3}{4}$ -in. (19.0-mm) sieve as appropriate for choosing Method A, B, or C. Make this determination by separating out a representative portion from the total sample and determining the percentages passing the sieves of interest by Test Methods D 422 or C 136. It is only necessary to calculate percentages for the sieve or sieves for which information is desired.

## 9. Preparation of Apparatus

9.1 Select the proper compaction mold in accordance with the Method (A, B, or C) being used. Determine and record its mass to the nearest gram. Assemble the mold, base and extension collar. Check the alignment of the inner wall of the mold and mold extension collar. Adjust if necessary.

9.2 Check that the rammer assembly is in good working condition and that parts are not loose or worn. Make any

necessary adjustments or repairs. If adjustments or repairs are made, the rammer must be recalibrated.

## 10. Procedure

### 10.1 Soils:

10.1.1 Do not reuse soil that has been previously compacted in the laboratory.

10.1.2 When using this test method for soils containing hydrated halloysite, or where past experience with a particular soil indicates that results will be altered by air drying, use the moist preparation method (see 10.2).

10.1.3 Prepare the soil specimens for testing in accordance with 10.2 (preferred) or with 10.3.

10.2 *Moist Preparation Method (preferred)*—Without previously drying the sample, pass it through a No. 4 (4.75-mm),  $\frac{3}{8}$ -in. (9.5-mm), or  $\frac{3}{4}$ -in. (19.0-mm) sieve, depending on the Method (A, B, or C) being used. Determine the water content of the processed soil.

10.2.1 Prepare at least four (preferably five) specimens having water contents such that they bracket the estimated optimum water content. A specimen having a water content close to optimum should be prepared first by trial additions of water and mixing (see Note 8). Select water contents for the rest of the specimens to provide at least two specimens wet and two specimens dry of optimum, and water contents varying by about 2 %. At least two water contents are necessary on the wet and dry side of optimum to accurately define the dry unit weight compaction curve (see 10.5). Some soils with very high optimum water content or a relatively flat compaction curve may require larger water content increments to obtain a well defined maximum dry unit weight. Water content increments should not exceed 4 %.

NOTE 8—With practice it is usually possible to visually judge a point near optimum water content. Typically, soil at optimum water content can be squeezed into a lump that sticks together when hand pressure is released, but will break cleanly into two sections when “bent”. At water contents dry of optimum soils tend to crumble; wet of optimum soils tend to stick together in a sticky cohesive mass. Optimum water content is typically slightly less than the plastic limit.

10.2.2 Use approximately 5 lbm (2.3 kg) of the sieved soil for each specimen to be compacted using Method A or B, or 13 lbm (5.9 kg) using Method C. To obtain the specimen water contents selected in 10.2.1, add or remove the required amounts of water as follows: to add water, spray it into the soil during mixing; to remove water, allow the soil to dry in air at ambient temperature or in a drying apparatus such that the temperature of the sample does not exceed  $140^\circ\text{F}$  ( $60^\circ\text{C}$ ). Mix the soil frequently during drying to maintain even water content distribution. Thoroughly mix each specimen to ensure even distribution of water throughout and then place in a separate covered container and allow to stand in accordance with Table 1 prior to compaction. For the purpose of selecting

**TABLE 1 Required Standing Times of Moisturized Specimens**

Classification	Minimum Standing Time, h
GW, GP, SW, SP	no requirement
GM, SM	3
All other soils	16

a standing time, the soil may be classified by Test Method D 2487, Practice D 2488 or data on other samples from the same material source. For referee testing, classification shall be by Test Method D 2487.

10.3 *Dry Preparation Method*—If the sample is too damp to be friable, reduce the water content by air drying until the material is friable. Drying may be in air or by the use of drying apparatus such that the temperature of the sample does not exceed 140°F (60°C). Thoroughly break up the aggregations in such a manner as to avoid breaking individual particles. Pass the material through the appropriate sieve: No. 4 (4.75 mm),  $\frac{3}{8}$  in. (9.5 mm), or  $\frac{3}{4}$  in. (19.0–mm). When preparing the material by passing over the  $\frac{3}{4}$ -in. sieve for compaction in the 6 in.-mold, break up aggregations sufficiently to at least pass the  $\frac{3}{8}$  in. sieve in order to facilitate the distribution of water throughout the soil in later mixing.

10.3.1 Prepare at least four (preferably five) specimens in accordance with 10.2.1.

10.3.2 Use approximately 5 lbm (2.3 kg) of the sieved soil for each specimen to be compacted using Procedure A or B, or 13 lbm (5.9 kg) using Method C. Add the required amounts of water to bring the water contents of the specimens to the values selected in 10.3.1. Follow the specimen preparation procedure specified in 10.2.2 for drying the soil or adding water into the soil and curing each test specimen.

10.4 *Compaction*—After curing, if required, each specimen shall be compacted as follows:

10.4.1 Determine and record the mass of the mold or mold and base plate.

10.4.2 Assemble and secure the mold and collar to the base plate. The mold shall rest on a uniform rigid foundation, such as provided by a cylinder or cube of concrete with a mass of not less than 200 lbm (91 kg). Secure the base plate to the rigid foundation. The method of attachment to the rigid foundation shall allow easy removal of the assembled mold, collar and base plate after compaction is completed.

10.4.3 Compact the specimen in five layers. After compaction, each layer should be approximately equal in thickness.

Prior to compaction, place the loose soil into the mold and spread into a layer of uniform thickness. Lightly tamp the soil prior to compaction until it is not in a fluffy or loose state, using either the manual compaction rammer or a 2 in. (50.8-mm) diameter cylinder. Following compaction of each of the first four layers, any soil adjacent to the mold walls that has not been compacted or extends above the compacted surface shall be trimmed. The trimmed soil may be included with the additional soil for the next layer. A knife or other suitable device may be used. The total amount of soil used shall be such that the fifth compacted layer slightly extends into the collar, but does not exceed  $\frac{1}{4}$  in. (6 mm) above the top of the mold. If the fifth layer does extend above the top of the mold by more than  $\frac{1}{4}$  in. (6 mm), the specimen shall be discarded. The specimen shall be discarded when the last blow on the rammer for the fifth layer results in the bottom of the rammer extending below the top of the compaction mold.

10.4.4 Compact each layer with 25 blows for the 4 in. (101.6 mm) mold or with 56 blows for the 6 in. (152.4 mm) mold.

NOTE 9—When compacting specimens wetter than optimum water content, uneven compacted surfaces can occur and operator judgment is required as to the average height of the specimen.

10.4.5 In operating the manual rammer, take care to avoid lifting the guide sleeve during the rammer upstroke. Hold the guide sleeve steady and within 5° of vertical. Apply the blows at a uniform rate of approximately 25 blows/min and in such a manner as to provide complete, uniform coverage of the specimen surface.

10.4.6 Following compaction of the last layer, remove the collar and base plate from the mold, except as noted in 10.4.7. A knife may be used to trim the soil adjacent to the collar to loosen the soil from the collar before removal to avoid disrupting the soil below the top of the mold.

10.4.7 Carefully trim the compacted specimen even with the top and bottom of the mold by means of the straightedge scraped across the top and bottom of the mold to form a plane surface even with the top and bottom of the mold. Initial trimming of the specimen above the top of the mold with a knife may prevent tearing out soil below the top of the mold. Fill any holes in either surface with unused or trimmed soil from the specimen, press in with the fingers, and again scrape the straightedge across the top and bottom of the mold. Repeat the appropriate preceding operations on the bottom of the specimen when the mold volume was determined without the base plate. For very wet or dry soils, soil or water may be lost if the base plate is removed. For these situations, leave the base plate attached to the mold. When the base plate is left attached, the volume of the mold must be calibrated with the base plate attached to the mold rather than a plastic or glass plate as noted in Annex A1 (A1.4.1).

10.4.8 Determine and record the mass of the specimen and mold to the nearest gram. When the base plate is left attached, determine and record the mass of the specimen, mold and base plate to the nearest gram.

10.4.9 Remove the material from the mold. Obtain a specimen for water content by using either the whole specimen (preferred method) or a representative portion. When the entire

**TABLE 2 Metric Equivalents for Figs. 1 and 2**

in.	mm
0.016	0.41
0.026	0.66
0.032	0.81
0.028	0.71
$\frac{1}{2}$	12.70
$2\frac{1}{2}$	63.50
$2\frac{5}{8}$	66.70
4	101.60
$4\frac{1}{2}$	114.30
4.584	116.43
$4\frac{3}{4}$	120.60
6	152.40
$6\frac{1}{2}$	165.10
$6\frac{5}{8}$	168.30
$6\frac{3}{4}$	171.40
$8\frac{1}{4}$	208.60
ft <sup>3</sup>	cm <sup>3</sup>
$\frac{1}{30}$ (0.0333)	943
0.0005	14
$\frac{1}{13.333}$ (0.0750)	2,124
0.0011	31

specimen is used, break it up to facilitate drying. Otherwise, obtain a portion by slicing the compacted specimen axially through the center and removing about 500 g of material from the cut faces. Obtain the water content in accordance with Test Method D 2216.

10.5 Following compaction of the last specimen, compare the wet unit weights to ensure that a desired pattern of obtaining data on each side of the optimum water content will be attained for the dry unit weight compaction curve. Plotting the wet unit weight and water content of each compacted specimen can be an aid in making the above evaluation. If the desired pattern is not obtained, additional compacted specimens will be required. Generally, one water content value wet of the water content defining the maximum wet unit weight is sufficient to ensure data on the wet side of optimum water content for the maximum dry unit weight.

**11. Calculation**

11.1 Calculate the dry unit weight and water content of each compacted specimen as explained in 11.3 and 11.4. Plot the values and draw the compaction curve as a smooth curve through the points (see example, Fig. 3). Plot dry unit weight to the nearest 0.1 lbf/ft<sup>3</sup> (0.2 kN/m<sup>3</sup>) and water content to the nearest 0.1 %. From the compaction curve, determine the optimum water content and maximum dry unit weight. If more than 5 % by weight of oversize material was removed from the sample, calculate the corrected optimum water content and corrected maximum dry unit weight of the total material using Practice D 4718. This correction may be made to the appropriate field in place density test specimen rather than to the laboratory test specimen.

11.2 Plot the 100 % saturation curve. Values of water content for the condition of 100 % saturation can be calculated as explained in 11.5 (see example, Fig. 3).

NOTE 10—The 100 % saturation curve is an aid in drawing the compaction curve. For soils containing more than approximately 10 % fines at water contents well above optimum, the two curves generally become roughly parallel with the wet side of the compaction curve between 92 % to 95 % saturation. Theoretically, the compaction curve cannot plot to the right of the 100 % saturation curve. If it does, there is an error in specific gravity, in measurements, in calculations, in testing, or in plotting.

NOTE 11—The 100 % saturation curve is sometimes referred to as the zero air voids curve or the complete saturation curve.

11.3 *Water Content, w*—Calculate in accordance with Test Method D 2216.

11.4 *Dry Unit Weights*—Calculate the moist density (Eq 1), the dry density (Eq 2), and then the dry unit weight (Eq 3) as follows:

$$\rho_m = \frac{(M_t - M_{md})}{1000 V} \tag{1}$$

where:

- $\rho_m$  = moist density of compacted specimen, Mg/m<sup>3</sup>,
- $M_t$  = mass of moist specimen and mold, kg,
- $M_{md}$  = mass of compaction mold, kg, and
- $V$  = volume of compaction mold, m<sup>3</sup>(see Annex A1).

$$\rho_d = \frac{\rho_m}{1 + \frac{w}{100}} \tag{2}$$

where:

- $\rho_d$  = dry density of compacted specimen, Mg/m<sup>3</sup>, and

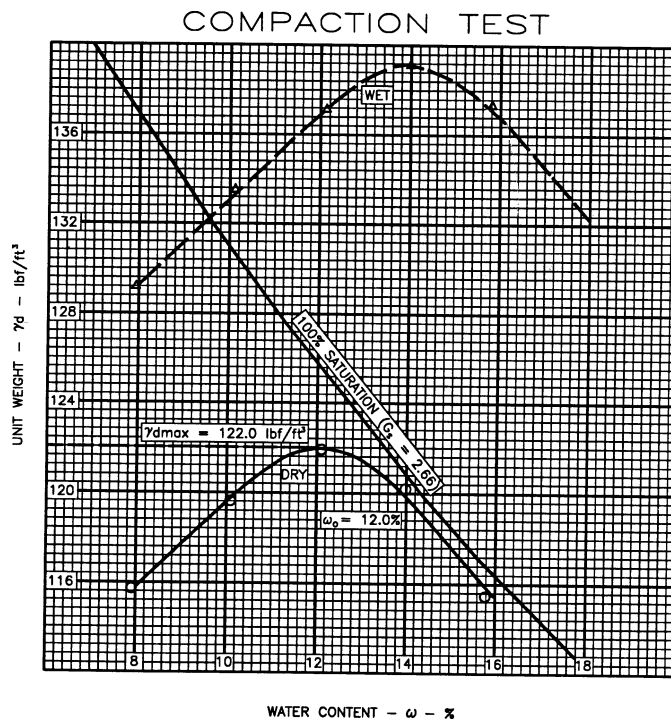

FIG. 3 Example Compaction Curve Plotting

$w$  = water content, % .

$$\gamma_d = 62.43 \rho_d \text{ in lbf/ft}^3 \quad (3)$$

or

$$\gamma_d = 9.807 \rho_d \text{ in kN/m}^3$$

where:

$\gamma_d$  = dry unit weight of compacted specimen.

11.5 To calculate points for plotting the 100 % saturation curve or zero air voids curve select values of dry unit weight, calculate corresponding values of water content corresponding to the condition of 100 % saturation as follows:

$$w_{\text{sat}} = \frac{(\gamma_w)G_s - \gamma_d}{(\gamma_d)(G_s)} \times 100 \quad (4)$$

where:

$w_{\text{sat}}$  = water content for complete saturation, %,

$\gamma_w$  = unit weight of water, 62.32 lbf/ft<sup>3</sup>(9.789 kN/m<sup>3</sup>) at 20°C,

$\gamma_d$  = dry unit weight of soil, lbf/ft (kN/m<sup>3</sup>), and

$G_s$  = specific gravity of soil.

NOTE 12—Specific gravity may be estimated for the test specimen on the basis of test data from other samples of the same soil classification and source. Otherwise, a specific gravity test (Test Method D 854) is necessary.

## 12. Report

12.1 Report the following information:

12.1.1 Method used (A, B, or C).

12.1.2 Preparation method used (moist or dry).

12.1.3 As-received water content, if determined.

12.1.4 Modified optimum water content, to the nearest 0.5 %.

12.1.5 Modified maximum (optimum) dry unit weight, to the nearest 0.5 lbf/ft<sup>3</sup>.

12.1.6 Description of rammer (manual or mechanical).

12.1.7 Soil sieve data when applicable for determination of Method (A, B, or C) used.

12.1.8 Description of material used in test, by Practice D 2488, or classification by Test Method D 2487.

12.1.9 Specific gravity and method of determination.

12.1.10 Origin of material used in test, for example, project, location, depth, and the like.

12.1.11 Compaction curve plot showing compaction points used to establish compaction curve, and 100 % saturation curve, point of maximum dry unit weight and optimum water content.

12.1.12 Oversize correction data if used, including the oversize fraction (coarse fraction),  $P_c$  in %.

## 13. Precision and Bias

13.1 *Precision*—Data are being evaluated to determine the precision of this test method. In addition, pertinent data is being solicited from users of the test method.

13.2 *Bias*—It is not possible to obtain information on bias because there is no other method of determining the values of modified maximum dry unit weight and optimum water content.

## 14. Keywords

14.1 compaction characteristics; density; impact compaction using modified effort; laboratory tests; modified proctor test; moisture-density curves; soil compaction

## ANNEX

### (Mandatory Information)

#### A1. VOLUME OF COMPACTION MOLD

##### A1.1 Scope

A1.1.1 This annex describes the method for determining the volume of a compaction mold.

A1.1.2 The volume is determined by a water-filled method and checked by a linear-measurement method.

##### A1.2 Apparatus

A1.2.1 In addition to the apparatus listed in Section 6, the following items are required:

A1.2.1.1 *Vernier or Dial Caliper*, having a measuring range of at least 0 to 6 in. (0 to 150 mm) and readable to at least 0.001 in. (0.02 mm).

A1.2.1.2 *Inside Micrometer*, having a measuring range of at least 2 to 12 in. (50 to 300 mm) and readable to at least 0.001 in. (0.02 mm).

A1.2.1.3 *Plastic or Glass Plates*—Two plastic or glass plates about 8 in.<sup>2</sup> by ¼ in. thick (200 mm<sup>2</sup> by 6 mm).

A1.2.1.4 *Thermometer*—0 to 50°C range, 0.5°C graduations, conforming to the requirements of Specification E 1.

A1.2.1.5 *Stopcock Grease* or similar sealant.

A1.2.1.6 *Miscellaneous equipment*—Bulb syringe, towels, etc.

##### A1.3 Precautions

A1.3.1 Perform this method in an area isolated from drafts or extreme temperature fluctuations.

##### A1.4 Procedure

A1.4.1 *Water-Filling Method*:

A1.4.1.1 Lightly grease the bottom of the compaction mold and place it on one of the plastic or glass plates. Lightly grease the top of the mold. Be careful not to get grease on the inside of the mold. If it is necessary to use the base plate, as noted in 10.4.7, place the greased mold onto the base plate and secure with the locking studs.

A1.4.1.2 Determine the mass of the greased mold and both plastic or glass plates to the nearest 0.01 lbm (1 g) and record. When the base plate is being used in lieu of the bottom plastic



or glass plate determine the mass of the mold, base plate and a single plastic or glass plate to be used on top of the mold to the nearest 0.01 lbm (1 g) and record.

A1.4.1.3 Place the mold and the bottom plate on a firm, level surface and fill the mold with water to slightly above its rim.

A1.4.1.4 Slide the second plate over the top surface of the mold so that the mold remains completely filled with water and air bubbles are not entrapped. Add or remove water as necessary with a bulb syringe.

A1.4.1.5 Completely dry any excess water from the outside of the mold and plates.

A1.4.1.6 Determine the mass of the mold, plates and water and record to the nearest 0.01 lbm (1 g).

A1.4.1.7 Determine the temperature of the water in the mold to the nearest 1°C and record. Determine and record the absolute density of water from Table A1.1.

A1.4.1.8 Calculate the mass of water in the mold by subtracting the mass determined in A1.4.1.2 from the mass determined in A1.4.1.6.

A1.4.1.9 Calculate the volume of water by dividing the mass of water by the density of water and record to the nearest 0.0001 ft<sup>3</sup>(1 cm<sup>3</sup>).

A1.4.1.10 When the base plate is used for the calibration of the mold volume repeat steps A1.4.1.3-A1.4.1.9.

**A1.4.2 Linear Measurement Method:**

A1.4.2.1 Using either the vernier caliper or the inside micrometer, measure the diameter of the mold six times at the

top of the mold and six times at the bottom of the mold spacing each of the six top and bottom measurements equally around the circumference of the mold. Record the values to the nearest 0.001 in. (0.02 mm).

A1.4.2.2 Using the vernier caliper, measure the inside height of the mold by making three measurements equally spaced around the circumference of the mold. Record values to the nearest 0.001 in. (0.02 mm).

A1.4.2.3 Calculate the average top diameter, average bottom diameter and average height.

A1.4.2.4 Calculate the volume of the mold and record to the nearest 0.0001 ft<sup>3</sup> (1 cm<sup>3</sup>) using Eq A1.1 (for inch-pound) or Eq A1.2 (for SI):

$$V = \frac{(\pi)(h)(d_t + d_b)^2}{(16)(1728)} \quad (A1.1)$$

$$V = \frac{(\pi)(h)(d_t + d_b)^2}{(16)(10^3)} \quad (A1.2)$$

where:

- $V$  = volume of mold, ft<sup>3</sup> (cm<sup>3</sup>),
- $h$  = average height, in. (mm),
- $d_t$  = average top diameter, in. (mm),
- $d_b$  = average bottom diameter, in. (mm),
- $1/1728$  = constant to convert in<sup>3</sup> to ft<sup>3</sup>, and
- $1/1000$  = constant to convert mm<sup>3</sup> to cm<sup>3</sup>.

**A1.5 Comparison of Results**

A1.5.1 The volume obtained by either method should be within the volume tolerance requirements of 6.1.1 and 6.1.2.

A1.5.2 The difference between the two methods should not exceed 0.5 % of the nominal volume of the mold.

A1.5.3 Repeat the determination of volume if these criteria are not met.

A1.5.4 Failure to obtain satisfactory agreement between the two methods, even after several trials, is an indication that the mold is badly deformed and should be replaced.

A1.5.5 Use the volume of the mold determined using the water-filling method as the assigned volume value for calculating the moist and dry density (see 11.4).

**TABLE A1.1 Density of Water<sup>A</sup>**

Temperature, °C (°F)	Density of Water, g/mL or g/cm <sup>3</sup>
18 (64.4)	0.99860
19 (66.2)	0.99841
20 (68.0)	0.99821
21 (69.8)	0.99799
22 (71.6)	0.99777
23 (73.4)	0.99754
24 (75.2)	0.99730
25 (77.0)	0.99705
26 (78.8)	0.99679

<sup>A</sup>Values other than shown may be obtained (5).

**REFERENCES**

- (1) *Earth Manual*, United States Bureau of Reclamation, Part 1, Third Edition, 1998, pp. 255-260.
- (2) *Earth Manual*, United States Bureau of Reclamation, Part 2, Third Edition, 1990.
- (3) Torrey, V.H., and Donaghe, R.T., "Compaction Control of Earth-Rock Mixtures: A New Approach," *Geotechnical Testing Journal*, GTJODJ, Vol 17, No 3, September 1994, pp. 371-386.
- (4) Johnson, A.W., and Sallberg, J.R., *Factors Influencing Compaction Test Results*, Highway Research Board, Bulletin 318, Publication 967, National Academy of Sciences-National Research Council, Washington, DC, 1962, p. 73.
- (5) *CRC Handbook of Chemistry and Physics*, David R. Lide, Editor-in-Chief, 74<sup>th</sup> Edition, 1993-1994

## SUMMARY OF CHANGES

In accordance with Committee D18 policy, this section identifies the location of changes to this standard since the last edition (2000) that may impact the use of this standard.

- (1) Added Practice D 3740 to Referenced Documents.
- (2) Added a new note on the use of Practice D 3740 to Section 5.
- (3) Revised the numbering of existing notes.
- (4) In Section 6.2 changed the SI tolerance for the height of drop of the rammer.

*ASTM International takes no position respecting the validity of any patent rights asserted in connection with any item mentioned in this standard. Users of this standard are expressly advised that determination of the validity of any such patent rights, and the risk of infringement of such rights, are entirely their own responsibility.*

*This standard is subject to revision at any time by the responsible technical committee and must be reviewed every five years and if not revised, either reapproved or withdrawn. Your comments are invited either for revision of this standard or for additional standards and should be addressed to ASTM International Headquarters. Your comments will receive careful consideration at a meeting of the responsible technical committee, which you may attend. If you feel that your comments have not received a fair hearing you should make your views known to the ASTM Committee on Standards, at the address shown below.*

*This standard is copyrighted by ASTM International, 100 Barr Harbor Drive, PO Box C700, West Conshohocken, PA 19428-2959, United States. Individual reprints (single or multiple copies) of this standard may be obtained by contacting ASTM at the above address or at 610-832-9585 (phone), 610-832-9555 (fax), or [service@astm.org](mailto:service@astm.org) (e-mail); or through the ASTM website ([www.astm.org](http://www.astm.org)).*